

524 Miniature Cartridge Fuse



Main Characteristics

Miniature Cartridge fuse; Time-Lag (T)

Standard

IEC 60127-2/V

Materials

Tube: Ceramic
End caps: Nickel-plated brass
Axial leads: Nickel-plated caps
Tin-plated copper wires

Operating Temperature

-55°C to +125°C

Storage Conditions

+10°C to +60°C
Relative humidity: ≤75% yearly average
without dew, maximum 30 days at 95%

Vibration Resistance

24 cycles at 15 min. each (60068-6)
10-60Hz at 0.75mm amplitude
60-2000Hz at 10g acceleration

Soldering Parameters

260°C. ≤5 sec (Wave Soldering)
350°C. ≤3 sec (Hand Soldering)

Soldering Peak:

260°C. 10 sec. (IEC 60068-20)

Average Current Curve (I-T Curve)

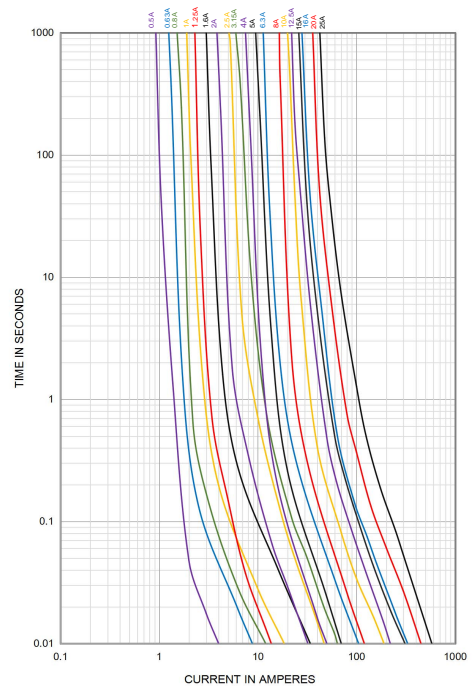

Dimensions (units in mm)

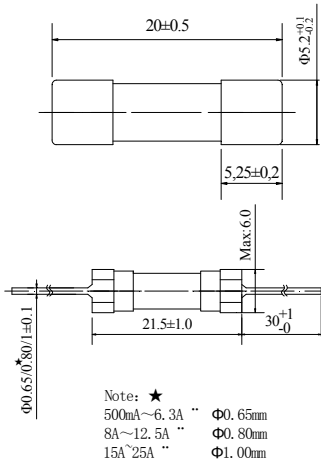

Time vs Current Characteristics: IEC 60127-2/V

Rated Current	150%	210%	275%	400%	1000%
500mA~800mA	>1h	<30min	250ms~80s	50ms~5s	5ms~150ms
1.00A~3.15A	>1h	<30min	750ms~80s	95ms~5s	10ms~150ms
4.00A~10.00A	>1h	<30min	750ms~80s	150ms~5s	10ms~150ms
12.00A~25.00A	>30min	<30min	750ms~80s	150ms~8s	10ms~150ms



Electrical Characteristics at 25°C

Amp	Rated Current	Rated Voltage	Max Voltage Drop(mV)	Max.Power Dissipation (W)	Typical Cold Resistance (mΩ)	Nominal Melting I ² t(A ² sec)	Breaking Capacity	Approvals										
								VDE	CCC	cURus	PSE	CQC	TUV	KC	BSI	SEMKO		
0500	500mA	125V AC 250V AC	850	1.6	450	0.16	10KA@125V AC 1500A@250V AC	•	•	•	○	○	○	○	○	○	○	
0630	630mA		650	1.6	320	0.774		•	•	•	○	○	○	○	○	○	○	○
0800	800mA		500	1.6	230	1.44		•	•	•	○	○	○	○	○	○	○	○
1100	1.00A		350	2.5	150	3.42		•	•	•	○	○	•	•	•	•	•	•
1125	1.25A		300	2.5	125	1.86		•	•	•	○	○	•	•	•	•	•	•
1160	1.60A		200	2.5	65.0	5.76		•	•	•	○	○	•	•	•	•	•	•
1200	2.00A		190	2.5	56.5	4.84		•	•	•	○	○	•	•	•	•	•	•
1250	2.50A		180	2.5	40.0	9.61		•	•	•	○	○	•	•	•	•	•	•
1315	3.15A		140	4	30.0	36.0		•	•	•	○	○	•	•	•	•	•	•
1400	4.00A		100	4	23.0	25.0		•	•	•	○	○	•	•	•	•	•	•
1500	5.00A		100	4	15.0	49.0		•	•	•	○	○	•	•	•	•	•	•
1630	6.30A		100	4	12.1	110		•	•	•	○	○	•	•	•	•	•	•
1800	8.00A		100	4	8.70	144		•	•	•	○	○	•	•	•	•	•	•
2100	10.00A		100	4	6.80	361		•	•	•	○	○	•	•	•	•	•	•
2120	12.00A		100	4	5.40	462		○	○	•	○	•	•	○	○	○	○	○
2125	12.50A		100	4	5.00	484		○	○	•	○	•	•	○	○	○	○	○
2150	15.00A		100	4	3.80	992		○	○	•	○	•	•	○	○	○	○	○
2160	16.00A		100	4	3.44	1090		○	○	•	○	•	•	○	○	○	○	○
2200	20.00A		100	4	2.40	2025	○	○	•	○	○	○	○	○	○	○	○	
2250	25.00A		100	4	1.90	3364	○	○	•	○	○	○	○	○	○	○	○	

- Note:** (1) Permissible continuous operating current is ≤100% at ambient temperature of 23°C (73.4°F)
 (2) The cURus certification by 125V and 250V; the others certification only by 250V.
 (3) The current values used for calculating I²t should be within the standard range of 8ms ~ 10ms.

Ordering Information

Series	Amp Code	Supplementary Code	Qty
524			